

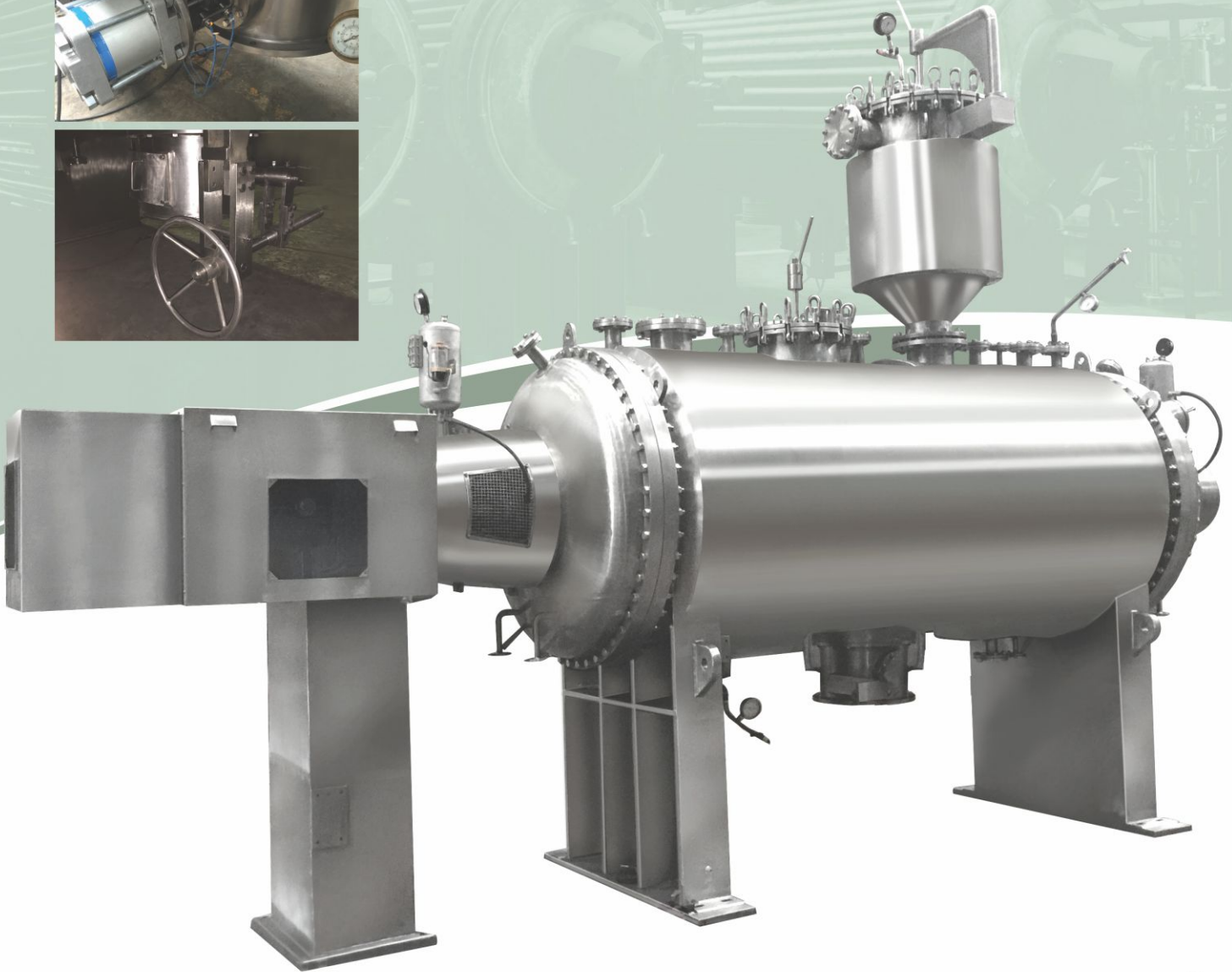

ASME "U" & "R" STAMP
AUTHORIZED MANUFACTURER



BEW Engineering Pvt. Ltd.
(A group company of Bifriends Engineering Works)

ROTARY VACUUM PADDLE DRYER

ROTARY VACUUM PADDLE DRYER

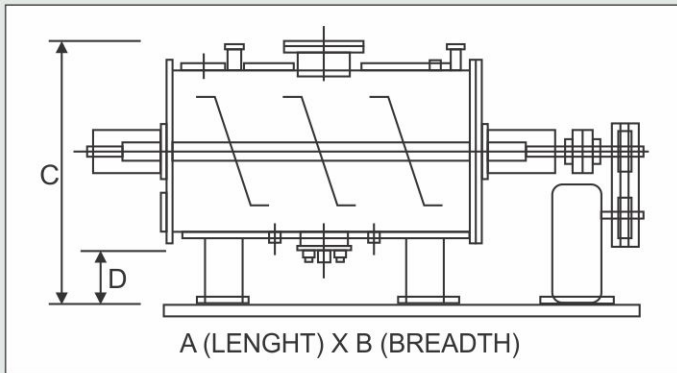

TECHNICAL DATE							
MODEL NO.	TOTAL VOLUME (Lits)	WORKING VOLUME (Lits.)	OVERALL DIMENSIONS (mm)				POWER (H.P.)
			A	B	C	D	
BEW-RVPD- 1	100	50	2250	650	1400	400	3
BEW-RVPD- 2	200	125	2350	750	1500	400	5
BEW-RVPD- 5	500	250	2800	900	1600	400	7.5
BEW-RVPD- 10	1000	500	3900	1050	1750	300	10
BEW-RVPD- 15	1500	750	4500	1150	1850	300	12.5
BEW-RVPD- 20	2000	1000	5500	1250	2000	300	15
BEW-RVPD- 30	3000	1500	6250	1350	2200	300	20
BEW-RVPD- 40	4000	2000	5800	1450	2300	200	25
BEW-RVPD- 50	5000	2500	7550	1500	2400	200	30
BEW-RVPD- 60	6000	3000	8250	1750	2500	200	30
BEW-RVPD- 80	8000	4000	8450	1800	2700	200	40
BEW-RVPD- 100	10000	5000	10000	1850	2800	200	50
BEW-RVPD- 120	12000	6000	10400	1950	3100	200	60
BEW-RVPD- 160	15000	7500	11100	2200	3500	200	75
BEW-RVPD- 200	20000	10000	11550	2700	4100	200	100
BEW-RVPD- 250	25000	13000	12000	3000	5300	200	150

NOTE : Design & Dimensions of above are subject to change without notice.

INTRODUCTION :

These dryers give drying, mixing and breaking effects simultaneously. Wet cake or slurry is fed through charging door, while the agitator is rotating in clockwise direction, Vacuum is applied in the dryer and heating media is circulated in the jacket. Evaporation of moisture takes place under vacuum and vapors passes through the dust catcher into the condenser, where it is condensed and collected in the receiver. Dried material is discharged through discharge valve. The lump breaker rods are provided to achieve good drying effect.

The unique quick opening discharge valve is operated by a hand wheel. This allows quick discharge of material and permits the dry product to be directly packed into convenient 25/50 kg bags or drums without loss of powder material.



CANTILEVER DESIGN

This Machine can be provided in a single support (Cantilever) Design for Pharma, Clean room, Isolator applications. We can provide this cantilever design up to capacity of 6000 lits total volume.

SALIENT FEATURES :

- Higher thermal efficiency due to the stirring action of product. high vacuum application and greater heat transfer area
- Improved product quality due to low temperature drying.
- Full recovery of solvent is achieved.
- Breaker bars are provided to break the lumps and disintegrate the particles size.
- Stellite or S.S. Surface is provided at gland packing area of shaft for its long life.
- Nitrogen purging arrangement is provided if necessary in stuffing box and at discharge point.
- Dust catcher cleaning arrangement with pulsation by nitrogen jet or air jet injector is provided.
- The design of paddles is such that reversal of electric motor direction is not necessary for discharging product. Hence the life of motor, gear box and equipment is increased.
- Dish end design is also manufactured on request.
- Sealing either stuffing box or mechanical seal with thermosiphon arrangement.

APPLICATION :

Drying of granules, Powder of chemicals, Pharmaceuticals, Bulk drugs, Pigments, Dyestuffs, Fish & Sea food under vacuum. Size available from 100 liters to 25,000 liters.

Variants

1. Isolator Compatible

RVPD's are available in variants compatible with barrier isolation systems at the discharge. This allows handling of Cytotoxic/ Potent products with operator safety. Additionally, these can be combined with automatic packing systems further downline. Also lab scale RVPD models are available for R&D purposes.

2. Sterile Construction

Sterile application RVPD models with completely automated SIP/CIP & operation cycles, sintered cartridge filter media, metal to metal sealing are also available.

3. Special Quick detachable designs for end cover



a) Super 'C' Bayonet

This design is similar to a TC clamp design but hydraulic operated. This facilitates quick end cover detachment for easy & fast maintenance. This design is good for vacuum and very low pressure applications.



b) Teethed Bayonet

This design has teethed body flanges, which are hydraulic operated and this is a 'Positive Locking' design. This facilitates quick end cover detachment for easy & fast maintenance. This design is good for vacuum as well as high pressure applications.

PILOT PLANT AVAILABLE FOR TRIAL



BEW Engineering Pvt. Ltd.

(A group company of Bifriends Engineering Works)

Office & Factory : FE-10, MIDC, Phase-II, Manpada Road, Dombivli (East),

Dist. Thane - 421 204 Maharashtra (India) • Phone : 91-251-2873335/8

Website : www.filterdryer.com, www.bifriendsengg.com • E-mail: bifriends@bew.net. in